

Installation Guide

This procedure is designed as an installation aid. Skilled tradespeople that are familiar with general construction and electrical installation techniques should perform the installation. Licensed electricians should provide electrical installation connections. Installations and connections should be done in accordance with all national and local codes and permits. In no way is this document intended to construe warranty or fitness of use of the products described, nor is it intended to provide safety instruction for those installing the product.

⚡ WARNING

Before proceeding with installation or service maintenance of this product.

- Disconnect power to reduce electrical shock risk.
- Review the entire Installation Guide.
- Inspect this properly packaged product for any damage that may have occurred during transit.
- Verify product application complies with manufacturer design recommendations.
- Verify the availability of necessary tools and incidental material.
- Verify applicable code requirements. Field assembly and installation are subject to acceptance by local inspection authority.
- Appropriate safety equipment to be determined by end user, per applicable safety standards and precautions.

Type-U Yoke Mount

Step 1: Before installation

- 1) Adjust the angle of 1 rotating shaft according to the result from simulation software.
- 2) With a torque of 142Nm, fasten 2 of M12 screws to the bottom cover of the fixture holder power box and the rotating shaft of the bracket.

The following tools are used:
Hex socket wrench or supporting special tool;
Wrench size: 10mm opposite side.

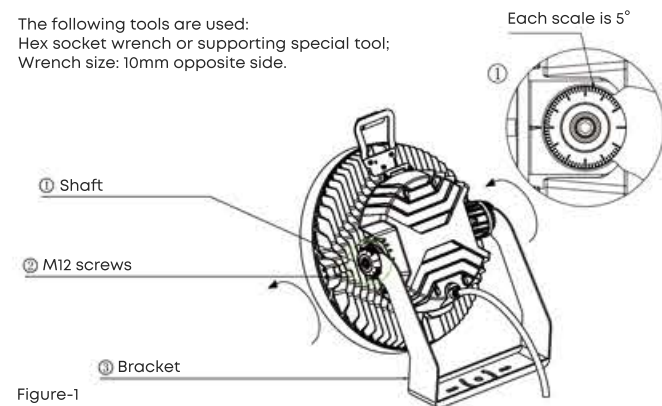

Figure-1

Step 2:

- 1) Fix the M20 screw on the pole of the site, and then adjust the bracket horizontally and fix according to the result from the software simulation, and then use the torque force of 685Nm to lock the M20 screw, as shown in Figure-2 & 3.

The following tools are used:
Hex socket wrench or supporting special tool;
Wrench size: 18mm opposite side.

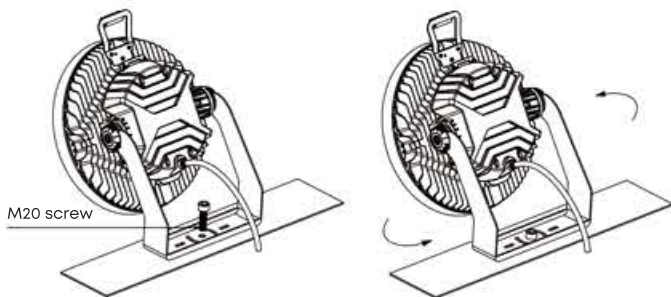

Figure-2 & 3

Step 3:

- 1) Fix two M10 screws with torque of 81 Nm on the arc-shaped holes on both sides of the fixture bracket respectively, as shown in figure-4 & 5.

The following tools are used:
Hex socket wrench or supporting special tool;
Wrench size: 8mm opposite side.

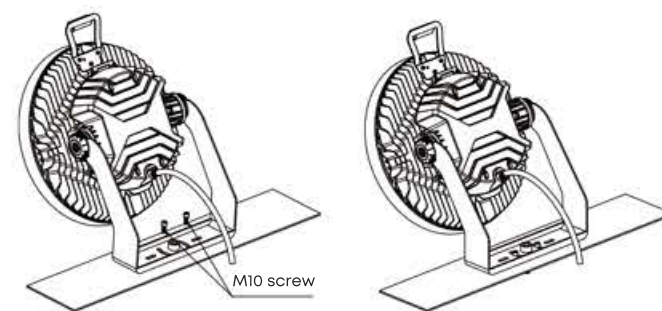

Figure-4 & 5

Step 4:

- 1) Fasten one end of the safety rope to the hand grip and the other end to the pole on site, as shown in Figure-6.

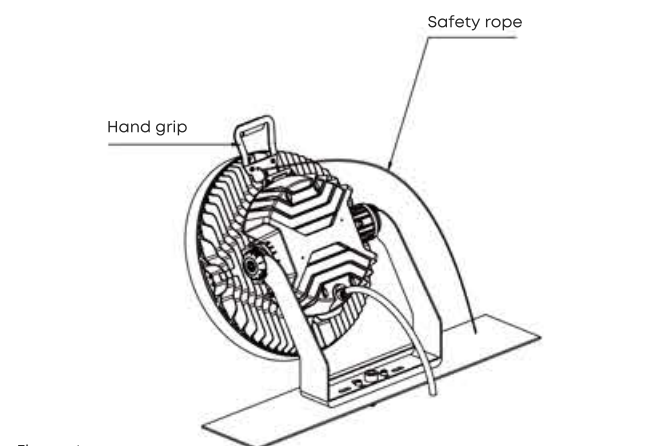

Figure-6

Type-A Top Fixed

Step 1: Preparation work before installation :

- 1) Adjust the Angle of lamp cap and fixed bracket according to the Angle of software simulation on the ground.
- 2) Fix the rotating bracket and the fixing bracket with M16 screws with a special tool and a torque of 350Nm.

The following tools are used:
Hex socket wrench or supporting special tool;
Wrench size: 14mm opposite side.

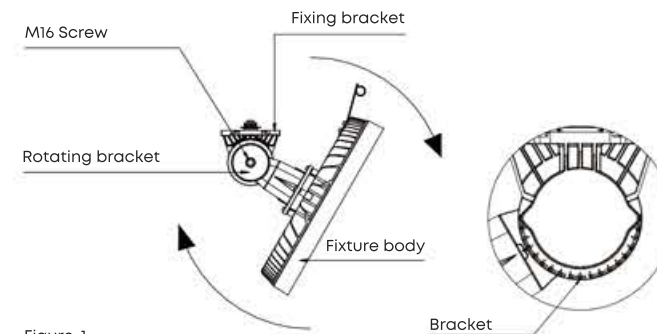

Figure-1

- 2) Adjust the mounting plate angle horizontally according to the result of software simulation, as shown in Figure-4.

- 3) Fix the mounting plate and the light pole with two M10 screws with a special tool and a torque of 81Nm, as shown in Figure-5.

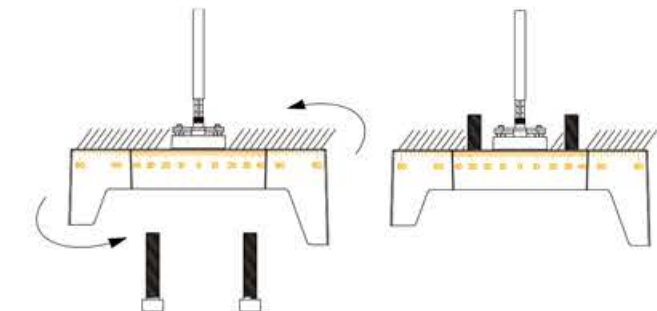

Figure-4 & 5

Step 3:

- Supplement: Fix the fixture body with the mounting plate using a special tool with a torque of 81Nm by using another 2 M10 screws, as shown in Figure - 8 & 9.

The following tools are used:
Hex socket wrench or supporting special tool;
Wrench size: 8mm opposite side.

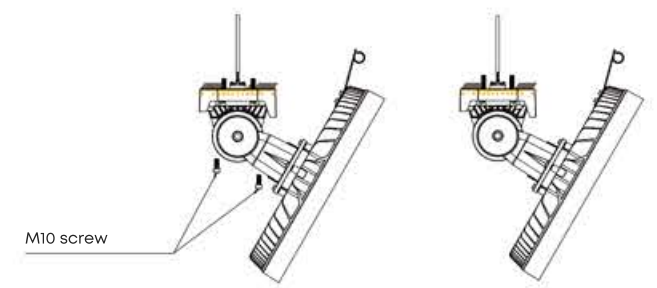

Figure-8 & 9

Step 2:

- 1) Connect the power cable to the wiring terminal of the installation plate, and use a flat-head screwdriver to tighten the screws fixing the terminal wire, as shown in Figure-2 & 3.

The following tools are used:
Hex socket wrench or supporting special tool;
Wrench size: 8mm opposite side.
Flat-head screwdriver: 3mm wide.

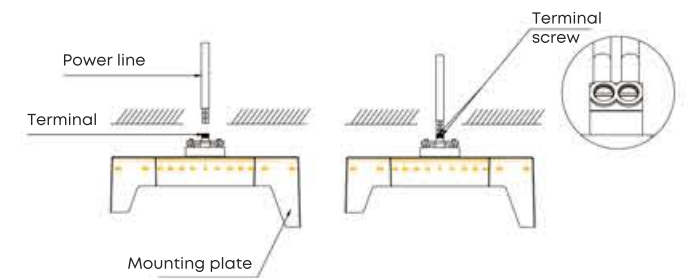

Figure-2 & 3

Step 3:

- 1) Fix the fixture body and mounting plate with 2 M10 screws using a special tool with a torque of 81Nm.

Supplement: Then fix the lamp cap with the mounting plate using a special tool with a torque of 81Nm using another 2 M10 screws. Figure - 8 & 9.

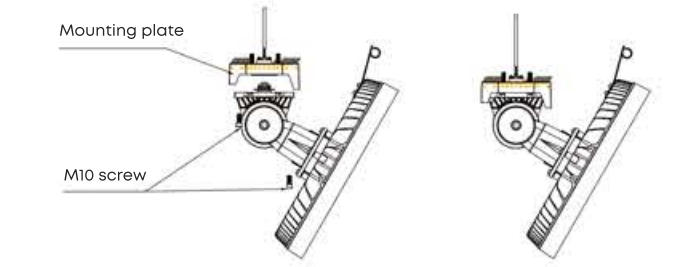

Figure-6 & 7

Step 4:

- Fasten the hand grip with the safety rope, and fasten the another end of the safety rope to an appropriate position on the pole or bar, as shown in Figure-10.

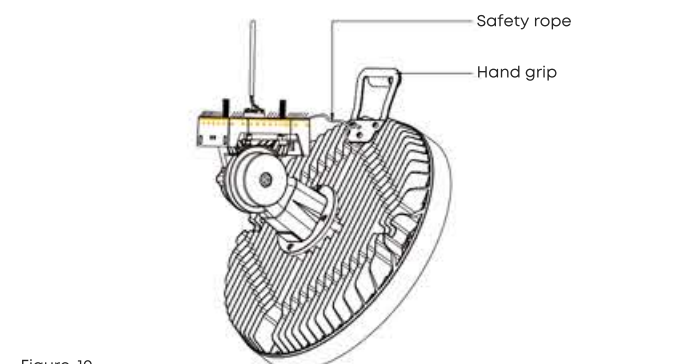

Figure-10